

# POWERFLEX®

## PART NUMBER

# PFF57-303

## DESCRIPTION

### FRONT WISHBONE REAR BUSH

## INSTALLATION GUIDE

### Contents (parts per pack):

- |                             |                             |
|-----------------------------|-----------------------------|
| 2 x Polyurethane Bushes     | 2x Plated Mild Steel Washer |
| 2 x Stainless Steel Sleeves | 2 x Stainless Steel Washers |
| 1 x PTFE/Silicone Grease    |                             |

Please read the complete fitting instructions and check package components before fitment. These fitting instructions are to be used as a guide and in conjunction with workshop manual.

It is recommended that:

- all work to be carried out by a licensed technician;
- all safety precautions adhered to;
- wheel alignment to be checked and adjusted as required after any suspension work.
- All fasteners must be tensioned to manufacturer's torque settings.



### Fitting Instructions:

1. Remove front lower suspension arm rear bush from the car, keeping the metal stud and original nut.
2. Remove the rubber from the metal bracket which needs to be reused. Ensure the bracket is clean and free from damage.
3. Fit the polyurethane bush into the original metal bracket.
4. Apply grease supplied to the bore of the bush and to the outside of the stainless steel sleeve. Push the sleeve into the bush.
5. Place the stainless steel washer onto the stud at the back of the arm. Fit the bush onto the stud, then place the supplied plated washer after the bush, and refit the nut.
6. Refit the bush back onto the car, and tighten fastenings to manufacturer's torque settings. Carry out wheel alignment checks.

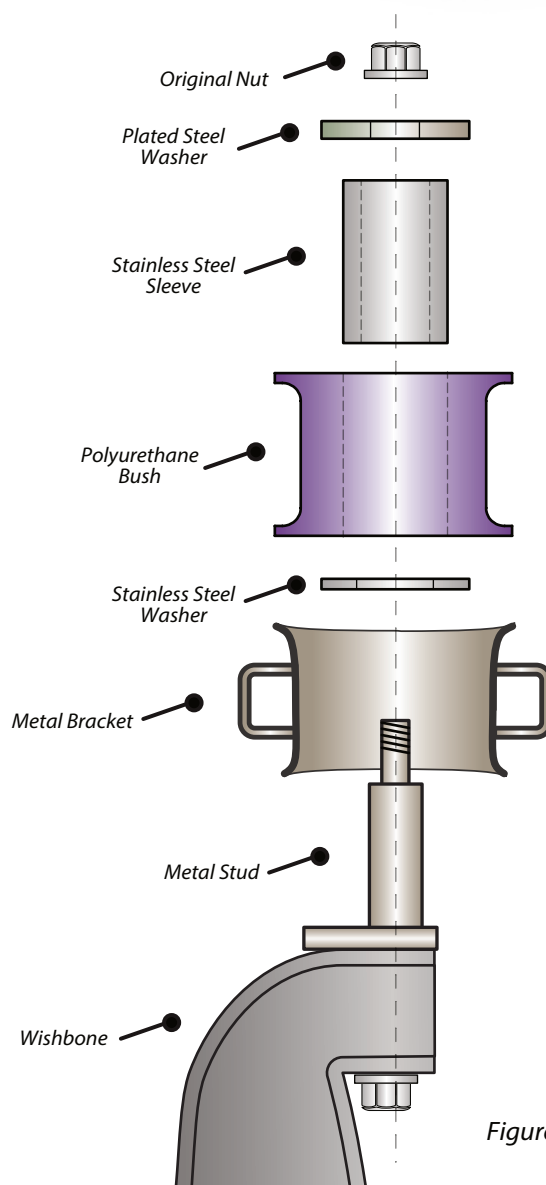

Figure 1